

<p>Number 200-BS / 200-BSW</p>	<p>Series CPS200 Optional Installation Brackets Pro Plus 200</p>
--------------------------------------------------	--------------------------------------------------------------------------------------------

Channel Bracket (1 needed for each joint in run.)

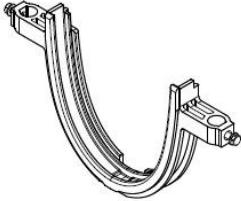

200-BS

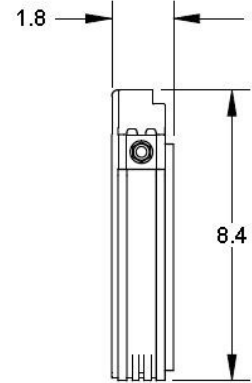
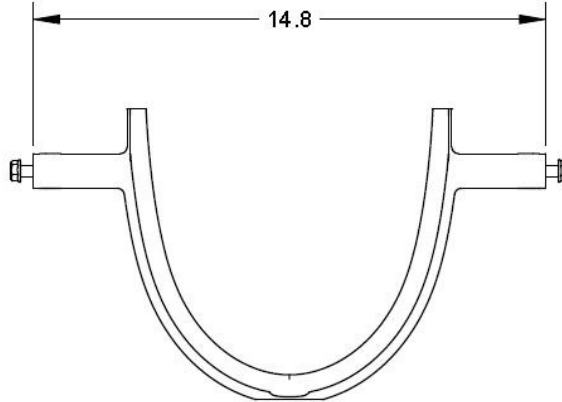

Male end support bracket (1 needed per run.)

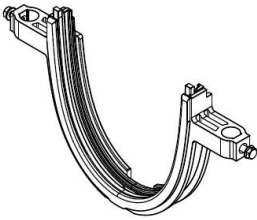

200-BSW

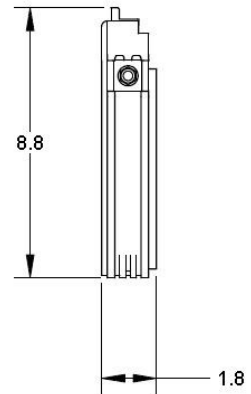
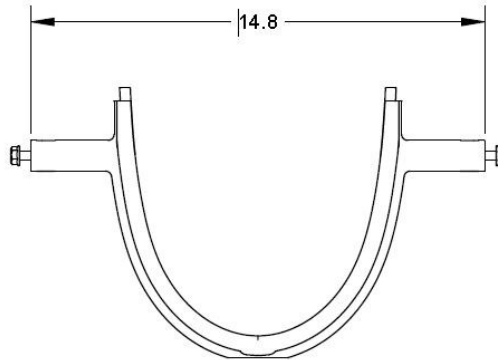

Manufacturer



Specification

JOSAM 200-BS AND 200 BSW SUPPORT BRACKETS FOR PRO-PLUS 200C 8" CHANNELS. MADE WITH PVC MATERIAL TO SUPPORT AND CONNECT CHANNEL SECTIONS AND WITH VERTICAL HOLES TO SECURE TO RE-BAR WITH INCLUDED BOLTS, TO BE SUPPLIED BY TRENCH DRAIN SUPPLY.

DISCLAIMER - The customer and the customer's architects, engineers, consultants, and other professionals are completely responsible for the selection installation and maintenance of any product purchased from Trench Drain Supply and/or its manufacturers. TRENCH DRAIN SUPPLY MAKES NO WARRANTY, EXPRESS OR IMPLIED, AS TO THE SUITABILITY, DESIGN, MERCHANTABILITY, OR FITNESS OF THE PRODUCT FOR CUSTOMERS APPLICATION. The drawing and information provided remain the property and copyright of the manufacturer listed. The manufacturer reserves the right to modify specification without notice.